

MQ-D305/D306 SERIES — INITIAL START-UP (ENGINE)

CAUTION - Read Manual

DO NOT attempt to operate the pump until the Safety, General Information and Inspection sections of this manual have been **read and thoroughly understood**.



This section is intended to assist the operator with the **initial start-up** of the diaphragm pump. It is extremely important that this section be read carefully before attempting to use the pump in the field.

Starting the Engine (HONDA engine)

1. Place the engine **fuel valve lever** (Figure 8) to the "ON" position.

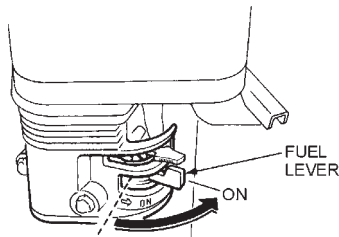

Figure 8. Engine Fuel Valve Lever (ON Position)

2. Move the **throttle lever** (Figure 9) away from the slow position, about 1/3 of the way toward the fast position.

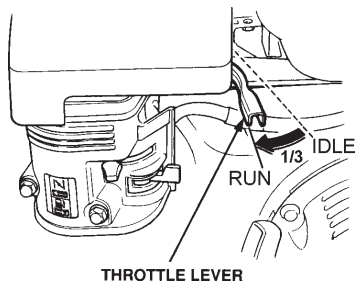

Figure 9. Throttle Lever (1/3 Start Position)

3. Place the **choke lever** (Figure 10) in the "OPEN" position if starting a **cold** engine.

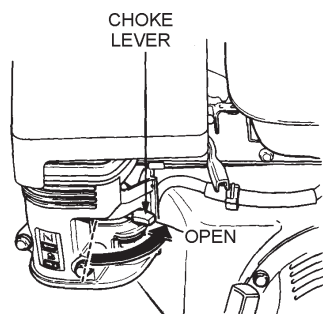

Figure 10. Engine Choke Lever (Open)

4. Place the **choke lever** (Figure 9) in the "CLOSED" position if starting a **warm engine** or the **temperature is warm**.

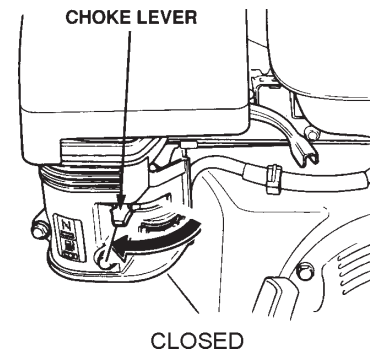

Figure 11. Engine Choke Lever (Closed)

5. Place the **engine ON/OFF switch** (Figure 12) in the "ON" position.

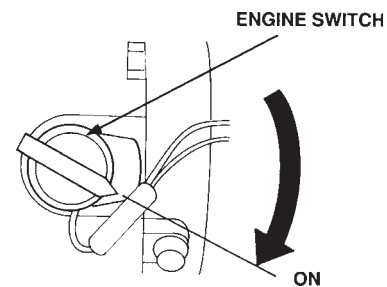

Figure 12. Engine ON/OFF Switch (ON Position)

6. Grasp the **starter grip** (Figure 13) and slowly pull it out. The resistance becomes the hardest at a certain position, corresponding to the compression point. Pull the starter grip briskly and smoothly for starting.

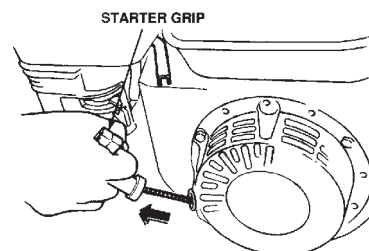

Figure 13. Starter Grip

MQ-D305/D306 SERIES — INITIAL START-UP (ENGINE)

7. If the engine has started, slowly return the choke lever (Figure 14) to the “CLOSED” position. If the engine has not started repeat steps 1 through 6.

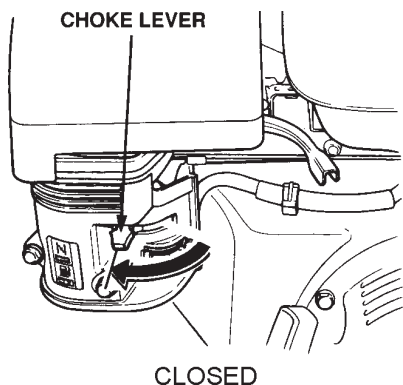

Figure 14. Choke Lever (Closed)

8. Before the pump is placed into operation, run the engine for several minutes. Check for fuel leaks, and noises that would associate with a loose component.
9. To begin pumping, place the throttle lever (Figure 15) in the "RUN" position.

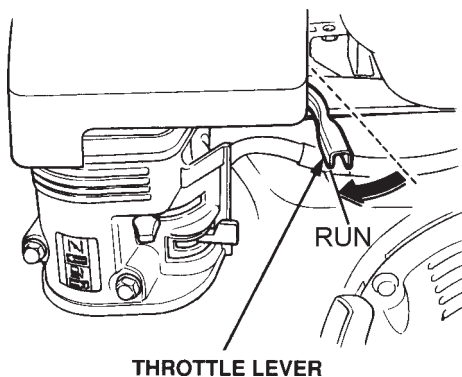
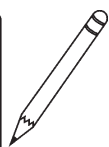
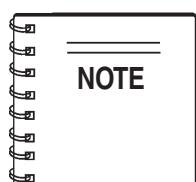

Figure 15. Throttle Lever (Run)



Pump speed can be **regulated** with the engine throttle control from full volume, 65 strokes per minute, to about 40 strokes per minute for lesser volume. Smoothest operation can be determined by trying to pump at several speeds. Limit maximum speed to 65 strokes per minute of the diaphragm (2,800 RPM engine speed).

Stopping The Engine

Normal Shutdown

1. Move the throttle lever to the **IDLE** position (Figure 16) and run the engine for three minutes at low speed.

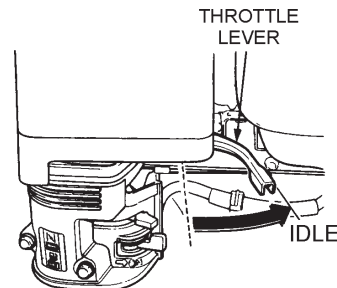

Figure 16. Throttle Lever (Idle)

2. After the engine **cools**, turn the engine ON/OFF switch to the “OFF” position (Figure 17).

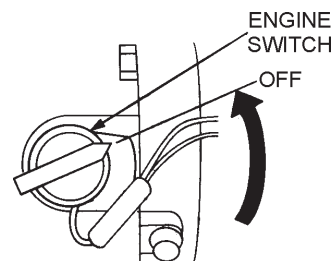

Figure 17. Engine ON/OFF Switch (OFF)

3. Place the **fuel shut-off lever** (Figure 18) in the “OFF” position.

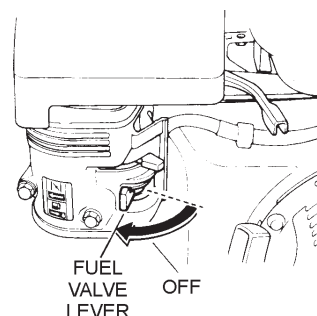

Figure 18. Fuel Valve Lever (OFF)

Emergency Showdown

1. Move the throttle lever quickly to the “**IDLE**” position, and place the engine ON/OFF switch in the “**OFF**” position.