



# 5500-LB. PALLET TRUCK

## OWNER'S MANUAL



**WARNING:** Read carefully and understand all INSTRUCTIONS before operating. Failure to follow the safety rules and other basic safety precautions may result in serious personal injury.

**Item# 35001**

Thank you very much for choosing a Roughneck™ Product! For future reference, please complete the owner's record below:

Model: \_\_\_\_\_ Purchase Date: \_\_\_\_\_

Save the receipt, warranty and these instructions. It is important that you read the entire manual to become familiar with this product before you begin using it.

This pallet truck is designed for certain applications only. The distributor cannot be responsible for issues arising from modification. We strongly recommend this pallet truck is not modified and/or used for any application other than that for which it was designed. If you have any questions relative to a particular application, DO NOT use the pallet truck until you have first contacted distributor to determine if it can or should be performed on the product.

For technical questions, please call **1-800-222-5381**.

 **WARNING: Read carefully and understand all INSTRUCTIONS before operating. Failure to follow the safety rules and other basic safety precautions may result in serious personal injury. Save these instructions in a safe place and on hand so that they can be read when required. Keep these instructions to assist in future servicing.**

## **INTENDED USE**

The pallet truck is designed for transportation of loads with a level, fixed base and may be used only on a firm and even surface, such as concrete or asphalt. The load must be on evenly distributed pallets, with the ideal loading mode such that the center of gravity of the load is at the central position of the fork.

## **TECHNICAL SPECIFICATIONS**

<b>Item#</b>	35001
<b>Capacity</b>	5500 lbs.
<b>Fork Length</b>	48 1/16 in. (1220mm)
<b>Width</b>	26 15/16 in. (685mm)
<b>Min./Max. Fork Height</b>	3 in. - 7 1/2 in.
<b>Front Wheel Size</b>	3 in.
<b>Rear Wheel Size</b>	7 in.
<b>Material of Wheels</b>	PU over Steel
<b>Width between Forks</b>	14 3/8 in. (365mm)

## **GENERAL SAFETY REGULATIONS**

 **WARNING: Read and understand all instructions.**

 **WARNING: The warnings, cautions, and instructions discussed in this instruction manual cannot cover all possible conditions or situations that could occur.** It must be understood by the operator that common sense and caution are factors that cannot be built into this product, but must be supplied by the operator.

- 1. Keep the work area clean and dry.** Damp or wet work areas can result in injury.

- 2. Keep children away from work area.** Do not allow children to handle this product.
- 3. Store idle equipment.** When not in use, tools and equipment should be stored in a dry location to inhibit rust. Always lock up tools and equipment, and keep out of reach of children.
- 4. Use the right tool for the job.** Do not attempt to force small equipment to do the work of larger industrial equipment. There are certain applications for which this pallet truck was designed. It will do the job better and more safely at the capacity for which it was intended. Do not modify this pallet truck, and do not use this equipment for a purpose for which it was not intended.
- 5. Check for damaged parts.** Before using this pallet truck, carefully check that it will operate properly and perform its intended function. Check for damaged parts and any other conditions that may affect the operation of this pallet truck. Replace damaged or worn parts immediately.
- 6. Do not overreach.** Keep proper footing and balance at all times to prevent tripping, falling, back injury, etc.
- 7. DO NOT use the pallet truck when tired or under the influence of drugs, alcohol, or medication.** A moment of inattention while operating this equipment may result in serious personal injury.
- 8. Industrial applications must follow OSHA requirements.**

## **SPECIFIC OPERATION WARNINGS**

 **WARNING:** To prevent personal injury, perform the Pressure Relief Procedure before and after operating the pump and before performing any disassembly or assembly.

 **WARNING:** Failure to comply with these warnings may result in severe injury or even death.

- Read and understand the entire owners manual before using the pallet truck.
- Do not place hands or feet under the pallet truck at any time.
- Never allow anyone to ride on the pallet truck.
- Operate on smooth, level, finished floors only; do not use on ramps or sloping floors.
- To prevent accidental tipping, make sure load is centered on the fork.
- Do not lift a load with fork tips only. This may cause damage to the forks and personal injury if the rear of the pallet truck suddenly tips upward.
- Do not load pallet truck beyond its rated capacity.
- Never leave a loaded pallet truck unattended in the raised position. Always lower the load to the floor.
- Pull pump release lever slowly to allow load to descend in a controlled manner.
- Secure load before transporting.
- Do not move a loaded pallet truck by other than manual force.
- The handle is designed to pull and steer the pallet truck only. Do not use the handle as a leverage tool.
- Failure to comply with these warnings may result in personal injury and/or property damage.

## **INSTALLATION**

**Tools required for assembly:**

- Allen Key
- Flat Head Screwdriver

1. Put the base of the HANDLE TUBE (Fig. 1) on the PRESSURE PLATE (Fig. 1). Align the holes (Fig. 1) at the base of the HANDLE with the holes in the PRESSURE PLATE. The chain should drop through the middle hole of SHAFT (Fig. 2).

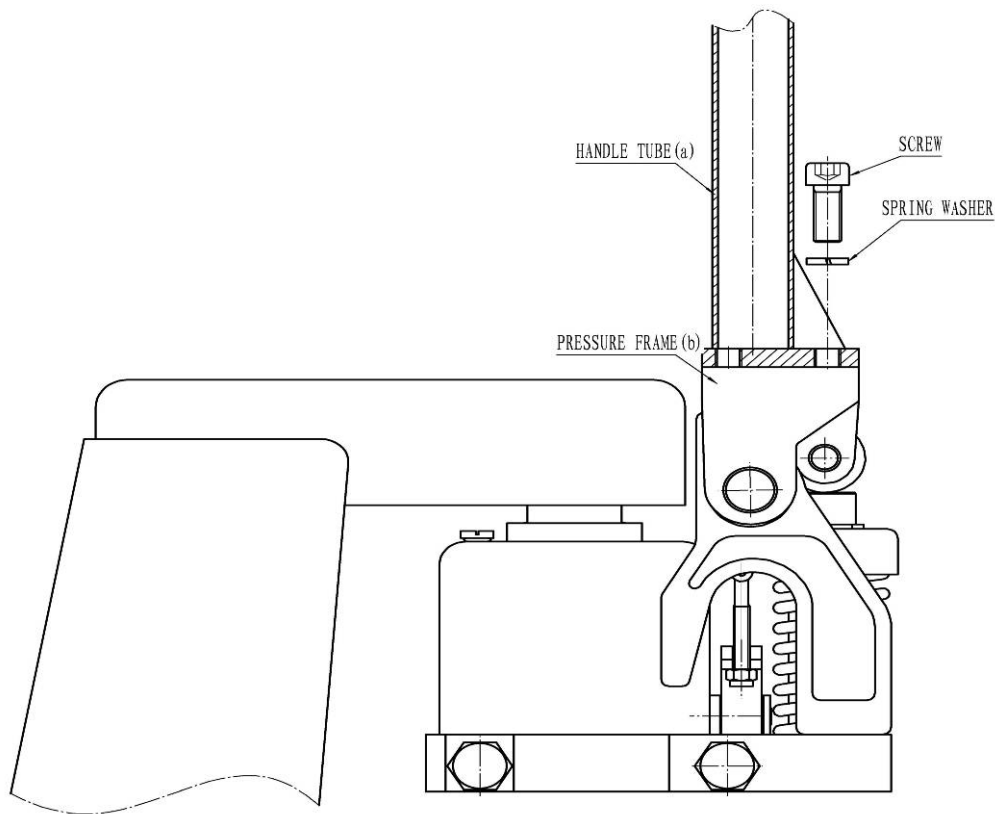

(Fig. 1)

2. Using a screwdriver, pry the LEVER PLATE (Fig. 2) up and slip the bolt head under the notch in the LEVER PLATE. **Do not adjust the nut unless the pallet truck doesn't work properly.**

**⚠️ WARNING: DO NOT LOOSEN OR OVER TIGHTEN THE LOCK NUT (12).** The nut is pre-locked on the bolt at the factory. If this lock nut is damaged or needs to be replaced, call customer service at 1-800-222-5381.

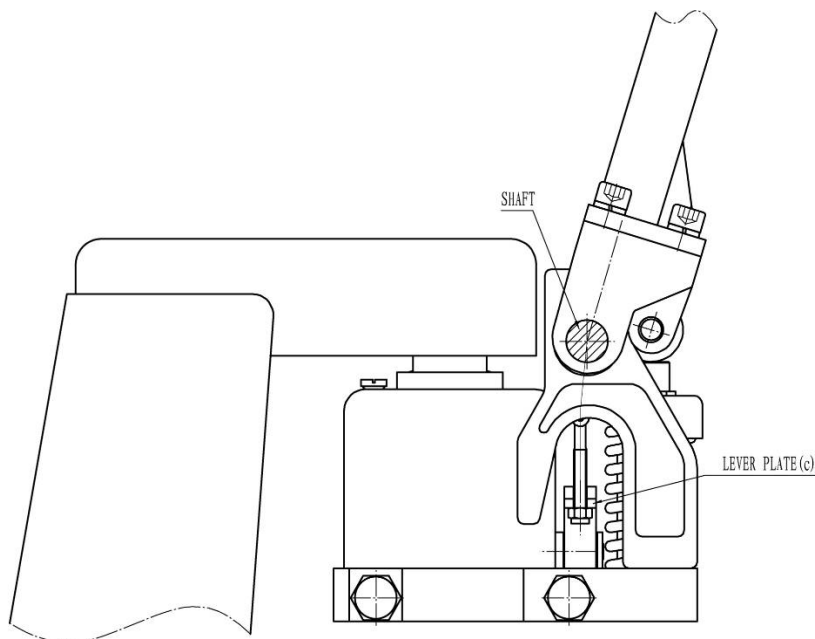

(Fig. 2)

3. Secure the HANDLE to the pallet truck by the three SPRING WASHERS and SCREWS (Fig. 1).

**NOTE:** It is a good idea to remove any air bubbles that might have accumulated in the hydraulic system during

shipping. Refer to “**BLEEDING THE AIR**” in “**MAINTENANCE**” section.

## **OPERATION INSTRUCTIONS**

**NOTE:** Numbers in parentheses refer to part numbers in the breakdown.

This pallet truck is designed for use with open style pallets or skids only. Closed style pallets must be placed on top of fork prior to use.

1. Insert the fork into the pallet.
2. To raise the fork, push control lever all the way down, and pump the handle until the desired fork height is reached.
3. To move the handle without affecting the fork setting, set the control lever in the center neutral position. The load can now be pushed or pulled using the handle.
4. To lower the fork, pull lever all the way up. Allow the load to descend slowly in a controlled manner. The lever is spring-loaded and will return to the neutral position when released.

**⚠ WARNING:** When not in use, do not allow heavy loads to remain on the fork for an extended period of time. Always lower fork completely when not in use.

### **ADJUSTING THE CONTROL HANDLE'S THREE POSITIONS**

On the Handle Tube (1) of this pallet truck, you can find the Control Lever (7), which can be regulated in three positions (See Fig. 3):

- LOWER** -Pull the Control Lever (7) up and the forks / load will lower to the desired height. The Control Lever (5) will move back the NEUTRAL position when released.
- NEUTRAL** -When the Control Lever (7) is in the middle position the forks will not move when the Handle Tube (1) is pumped. The Control Lever (7) must be in the neutral position when the truck is driven.
- LIFT** -Push the Control Lever (7) down and pump the Handle Tube (1) to raise the forks / load to the desired height.

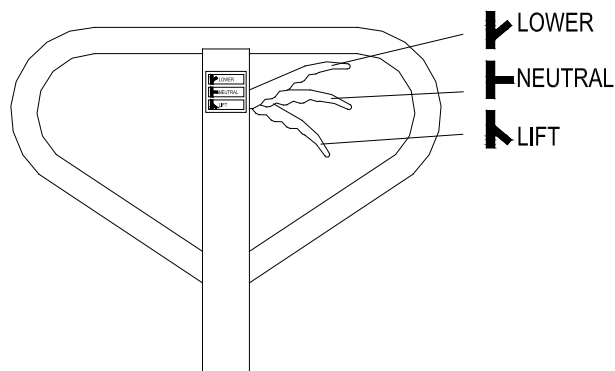

**Fig. 3**

**NOTE:** These three positions have been set at the factory to work appropriately as soon as the handle tube is attached. Check to see if the truck works well in the 3 control positions. If the forks do not raise or lower as expected, proceed to the following steps (see Fig. 4):

1. Pull the Control Lever (7) upward to the "LOWER" position. If the fork frame does not lower, turn the Nut (12) CLOCKWISE until the fork frame lowers.
2. Push the Control Lever (7) down to the "LIFT" position. If the fork frame does not elevate, turn the Nut (12) COUNTERCLOCKWISE until the fork frame elevates.
3. Keep the control handle in "NEUTRAL" position. If the fork frame lowers, turn the Nut (12) COUNTERCLOCKWISE until the fork frame does not lower.

4. Check again to see if the truck works well in the 3 control positions. If not, repeat the steps above until the pallet truck works well.

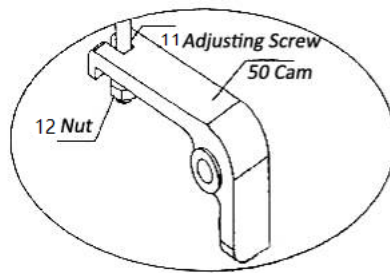

Fig. 4

**⚠️ WARNING:** Only use this pallet truck for loads weighing less than the rated loading capacity (5500 lbs.) To avoid serious bodily injury or death, and/or property damage, there is overload protection in this pallet truck. It will stop working automatically when the load is over loading capacity.

## MAINTENANCE

### 1. OIL

Check the oil level annually by removing the oil plug (53) on top of the pump housing. When changing or adding oil, fill the tank through the oil plug hole with 0.26L of new hydraulic jack oil. See Figure 5. Do not use any other type of oil. When finished, replace oil plug (53).

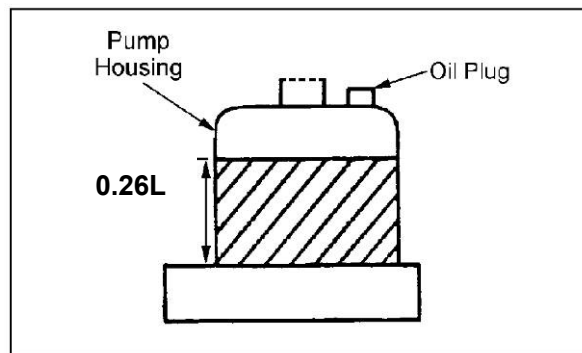

Fig. 5

### 2. LUBRICATION

Wheel bearings are sealed and require no lubrication. The crankshaft features "oil lite" bushings that also require no lubrication.

Lightly oil all other moving parts.

### 3. BLEEDING THE AIR

There may be times when the forks do not rise while pumping when in the "LIFT" position. Most likely this is because air has been introduced in to the hydraulic system. The air can be removed by moving the control handle to the "LOWER" position, then pumping the handle up and down several times. Repeat this process until the forks lift as intended.

### 4 SEAL AND O-RING REPLACEMENT FOR RAM AND PLUNGER PISTON

- ①. Raise the pallet truck by pumping handle.
- ②. Remove shaft (20). This will free the pump and handle assembly from the pallet truck.
- ③. Remove the oil plug (53), turn pump over and empty the oil into a suitable container. Pump handle until all oil has drained. Dispose of used hydraulic oil according to local disposal regulations.
- ④. Pull out plunger piston (59) and/or ram piston (57).
- ⑤. Remove all O-rings and seals. See Fig. 6.
- ⑥. Insert new O-ring or seal one at a time making sure to replace with the same size that was removed.

- ⑦. Reassemble and fill the oil tank through the oil plug hole with 0.26L (8.8 oz.) of new hydraulic jack oil. See Fig. 5.

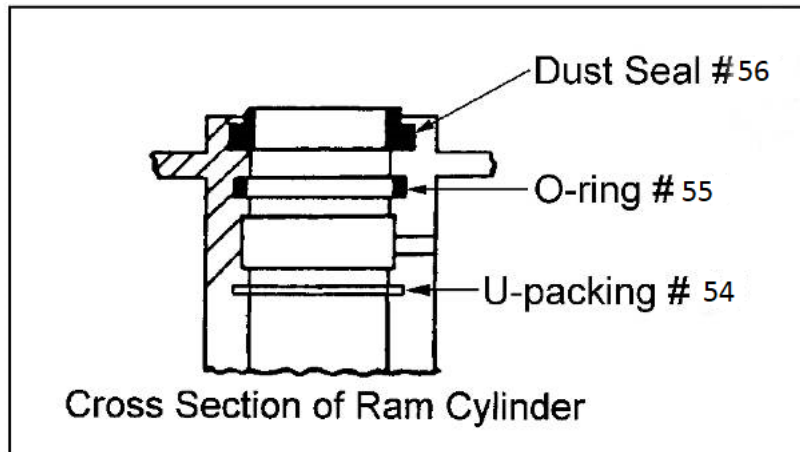

Fig. 6

### 5 DAILY INSPECTION AND MAINTENANCE

Daily inspection and maintenance of the pallet truck is required, especially for the wheels and the axles. Remove thread or rags on the wheel or axle if any is detected. Unload and lower the forks to the lowest position after every job is finished.

## TROUBLE SHOOTING

Numbers in parentheses refer to item numbers in the breakdown.

Trouble	Probable Cause	Remedy
The forks cannot raise completely	Insufficient oil	Refill oil (See instructions above).
Hydraulic unit does not lift	Low oil level	Refill oil (See instructions above).
	Air in pump	See " <b>BLEEDING THE AIR</b> ".
	Worn O-ring in ram cylinder	Replace O-ring (refer to " <b>Seal and O-Ring Replacement</b> ").
The forks do not descend	Deformed piston rod	Replace piston rod and cylinder.
	Piston rod rusted	Lubricate/ replace rod. Keep jack in lowered position when not in use.
	Handle tube, nut or chain broken or missing	Replace the handle tube.
Once lifted, truck lowers by itself	Air comes into the oil	See " <b>BLEEDING THE AIR</b> ".
	Worn O-ring in ram cylinder	Replace O-ring (refer to " <b>Seal and O-Ring Replacement</b> ").
	Pallet truck loaded beyond capacity	Reduce load to within capacity.
	Damaged push rods and/or linkages	Replace damaged parts. (It is recommended that an authorized service center perform this work.)
Fluid leak	Component, likely seal, worn or damaged	Inspect and replace worn or damaged parts.

# DIAGRAMS AND PARTS LIST

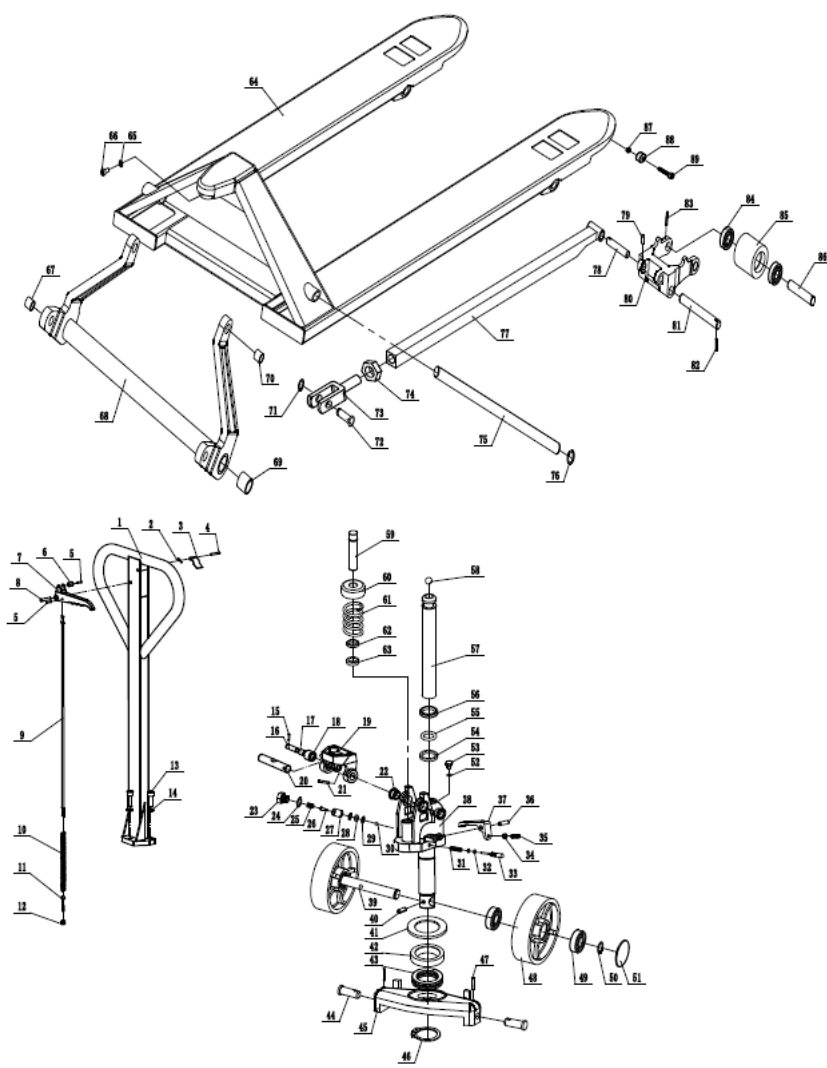

Part No.	Description	Qty.
1	Handle Tube	1
2	Spring	1
3	Blade Spring	1
4	Elastic Pin	1
5	Elastic Pin	2
6	Roller	1
7	Control Lever	1
8	Elastic Pin	1
9	Pull Rod	1
10	Chain	1
11	Adjusting Screw	1

Part No.	Description	Qty.
31	Release Nozzle Spring	1
32	O-Ring	2
33	Release Nozzle	1
34	Nut	1
35	Adjusting Screw	1
36	Elastic Pin	1
37	Lever Plat	1
38	Pump Housing Assy	1
39	Steering Wheel Axle Shaft	1
40	Elastic Pin	1
41	washer	1

Part No.	Description	Qty.
61	Spring	1
62	Dust Seal Ring	1
63	U-Packing	1
64	Fork Frame	1
65	spring washer	1
66	Socket Head Cap Screw	1
67	Oil Lite Bushing	2
68	Lifting Yoke	1
69	Oil Lite Bushing	2
70	Oil Lite Bushing	2
71	C-ring	2



12	Nut	1
13	Screw	1
14	Spring Washer	1
15	Elastic Pin	1
16	Shaft	1
17	Oil Lite Bushing	1
18	Pressure Roller	1
19	Pressure Frame	1
20	Shaft	1
21	Elastic Pin	1
22	Oil Lite Bushing	2
23	Release Plug	1
24	Washer	1
25	Spring	1
26	Tapered Column	1
27	Valve Base	1
28	O-Ring	1
29	Oil Baffe Washer	2
30	Steel Ball	1

42	Bearing Base	1
43	Ball Bearing	1
44	Table Pin	2
45	Thrust Plate	1
46	C-ring	1
47	Elastic Pin	2
48	Steering Wheel	2
49	Ball Bearing	4
50	Snap Ring	2
51	Dust Seal Cap	2
52	O-Ring	1
53	Oil Plug	1
54	U-Packing	1
55	O-Ring	1
56	Dust Seal Ring	1
57	Ram Piston	1
58	Steel Ball	1
59	Plunger Piston	1
60	Spring Cap	1

72	Crank Pin	2
73	Joint	2
74	Nut	2
75	Crank Shaft	1
76	C-ring	2
77	Push Rod	2
78	Rod Pin	2
79	Spring Pin	2
80	Load Wheel Frame	2
81	Arm Pin	2
82	Spring Pin	2
83	Spring Pin	2
84	Ball Bearing	4
85	Load Wheel	2
86	Load Wheel Axle	2
87	Nut	2
88	Enter Roller	2
89	Bolt	2

For replacement parts and technical questions, please call **1-800-222-5381**.

**WARRANTY**

One-Year Limited Warranty



Distributed by  
 Northern Tool + Equipment Co., Inc.  
 Burnsville, MN 55306  
 NorthernTool.com  
 Made in China