

ATTENTION : USERS OF HITACHI NAILERS **(Read this leaflet carefully for your satisfaction and safety)**

This Hitachi nailer has a STANDARD CONTACT TRIP MECHANISM (Bounce Fire). An OPTIONAL SEQUENTIAL TRIP MECHANISM kit (SINGLE SHOT) is available as shown below.

Models	Order part number
NR83A, NR83AA, NV83A, NV65AC, VH650 NT65A2, NV50AA, NV50A1, NV50AP	876762
NV45AB	878226
NR90AC, NV65AH, NR90AA	881973
NT65AA, NT65MA	880414

To order in U.S. call toll free 1-800-706-7337. In Canada call toll free 1-800-970-2299.

THE STANDARD CONTACT TRIP MECHANISM (Bounce Fire) is for use where rapid fastener placement is desired and must be operated in accordance with the following "Methods of Operation".

This Hitachi nailer is equipped with a push lever and does not operate unless the push lever is depressed (upward position). There are two methods of operation to drive nails with this Nailer.

1. Intermittent operation (Trigger Fire)
2. Continuous operation (Push Lever Fire)

(1) Intermittent operation (Trigger Fire)

- ① Position the nail outlet on the workpiece with finger off the trigger.
- ② Depress the push lever firmly until it is completely depressed.
- ③ Pull the trigger to drive a nail.
- ④ Remove finger from the trigger.

To drive another nail, move the nailer along the workpiece and repeat this procedure.

(2) Continuous operation (Push Lever Fire)

- ① Pull the trigger with the push lever pointing towards but not touching the workpiece.
- ② Depress the push lever against the workpiece to drive a nail.
- ③ Move the nailer along the workpiece with a bouncing motion. Each depression of the push lever will drive a nail.

As soon as the desired number of nails have been driven, remove finger from the trigger.

WARNING : Keep your finger off the trigger except during fastening operation, because serious injury could result if the push lever accidentally contacts you or others in work area.

WARNING : Keep hands and body away from the discharge area. The nailer with contact trip mechanism may bounce from the recoil of driving a fastener and unwanted subsequent fastener may be driven, possibly causing injury.

THE OPTIONAL SEQUENTIAL TRIP MECHANISM (SINGLE SHOT PARTS) is for use where precision fastener placement is desired and must be operated in accordance with the following "Method of Operation".

You must first depress the push lever (upward position) where you want to drive a nail and then pull the trigger. After the each nail is driven, completely release the trigger and lift the tool off the work surface. An OPTIONAL SEQUENTIAL TRIP MECHANISM may reduce the possibility of bodily injury to you or others in the work area. This is because it is less likely to drive an unwanted nail if you keep the trigger pulled and accidentally bump the push lever against yourself or others. An OPTIONAL SEQUENTIAL TRIP MECHANISM may also reduce the speed of operation compared to the standard contact trip mechanism.

NOTE : Both STANDARD CONTACT TRIP MECHANISM and OPTIONAL SEQUENTIAL TRIP MECHANISM are safe if used as described above and according to all warnings and instructions.

HITACHI

MODEL
MODÈLE **NT 65A2**
MODELO

FINISH NAILER
CLOUEUR DE FINITION
MARTILLO NEUMATICO PARA ACABADO

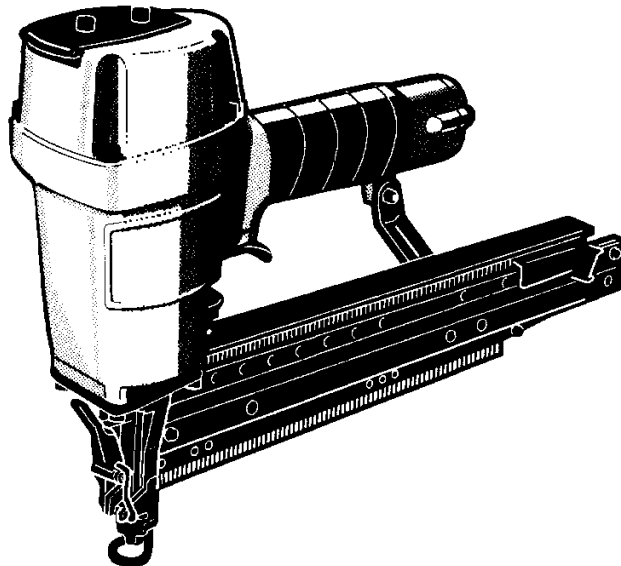

INSTRUCTION MANUAL AND SAFETY INSTRUCTIONS

DANGER

Improper and unsafe use of this Nailer will result in death or serious injury !
This Manual contains important information about product safety.
Read and understand this Manual before operating the Nailer.
Keep this Manual available for others before they use the Nailer.

MODE D'EMPLOI ET INSTRUCTIONS DE SECURITE

DANGER

Une utilisation incorrecte et sans respecter la sécurité de ce cloueur risque d'entraîner la mort ou des blessures graves !
Ce manuel renferme des instructions importantes sur la sécurité de l'outil.
Lire et bien assimiler ce manuel avant d'utiliser le cloueur.
Conserver ce manuel à l'intention des autres utilisateurs du cloueur.

MANUAL DE INSTRUCCIONES E INSTRUCCIONES DE SEGURIDAD

PELIGRO

¡La utilización inadecuada e insegura de este martillo neumático puede resultar en lesiones serias o en la muerte !
Este manual contiene información importante sobre la seguridad del producto.
Lea y entienda este manual antes de utilizar el martillo neumático.
Guarde este manual a mano para que puedan consultarlo otras personas antes de utilizar el martillo neumático.

CONTENTS

English	page	page	
IMPORTANT INFORMATION	3	BEFORE OPERATION	10
DEFINITIONS OF SIGNAL WORDS	3	WORKING ENVIRONMENT	10
SAFETY		AIR SUPPLY	10
IMPORTANT SAFETY INSTRUCTIONS		LUBRICATION	12
FOR USING NAILERS	4	COLD WEATHER CARE	13
EMPLOYER'S RESPONSIBILITIES	7	TESTING THE NAILER	13
OPERATION		ADJUSTING AIR PRESSURE	15
NAME OF PARTS	8	LOADING NAILS	15
SPECIFICATIONS	8	NAILER OPERATION	16
NAIL SELECTION	9	METHODS OF OPERATION	17
ACCESSORIES	9	USING THE NOSE CAP	18
STANDARD ACCESSORIES	9	MAINTENANCE	
OPTIONAL ACCESSORIES	10	MAINTENANCE AND INSPECTION	19
APPLICATIONS	10	SERVICE AND REPAIRS	20

TABLE DE MATIERES

Français	page	page	
INFORMATION IMPORTANTE	22	AVANT L'UTILISATION	30
DEFINITION DES MOTS DE SIGNALISATION	22	ENVIRONNEMENT DE TRAVAIL	30
SECURITE		ALIMENTATION D'AIR	30
CONSIGNES DE SECURITE IMPORTANTES		GRAISSAGE	32
POUR L'UTILISATION DU CLOUEUR	23	ENTRETIEN PAR TEMPS FROID	33
RESPONSABILITES DE L'EMPLOYEUR	27	ESSAI DU CLOUEUR	33
UTILISATION		REGLAGE DE LA PRESSION D'AIR	35
NOM DES PEICES	28	CHARGEMENT DES CLOUS	35
SPECIFICATIONS	28	UTILISATION DU CLOUEUR	36
SELECTION DES CLOUS	29	MÉTHODES D'UTILISATION	37
ACCESSOIRES	29	UTILISATION DU CAPUCHON DE BEC	38
ACCESSOIRES STANDARD	29	ENTRETIEN	
ACCESSOIRES EN OPTION	30	ENTRETIEN ET INSPECTION	39
APPLICATIONS	30	ENTRETIEN ET REPARATIONS	40

ÍNDICE

Español	Página	Página	
INFORMACIÓN IMPORTANTE	42	ANTES DE LA OPERACIÓN	50
DEFINICIÓN DE LAS PALABRAS CLAVE	42	ENTORNO DE TRABAJO	50
SEGURIDAD		SUMINISTRO DE AIRE	50
INSTRUCCIONES IMPORTANTES DE SEGURIDAD PARA		LUBRICACIÓN	52
LA UTILIZACIÓN DEL MARTILLO NEUMÁTICO	43	CUIDADOS PARA CLIMAS FRÍOS	53
RESPONSABILIDADES DEL EMPRESARIO	47	PRUEBA DEL MARTILLO NEUMÁTICO	53
OPERACIÓN		AJUSTE DE LA PRESIÓN DE AIRE	55
NOMENCLATURA	48	CARGA DE PUNTAS	55
ESPECIFICACIONES	48	OPERACIÓN DEL MARTILLO NEUMÁTICO	56
SELECCIÓN DE PUNTAS	49	MÉTODOS DE OPERACIÓN	57
ACCESORIOS	49	UTILIZACIÓN DE LA TAPA PARA EL MORRO	58
ACCESORIOS ESTÁNDAR	49	MANTENIMIENTO	
ACCESORIOS OPCIONALES	50	MANTENIMIENTO E INSPECCIÓN	59
APLICACIONES	50	SERVICIO Y REPARACIONES	60

IMPORTANT INFORMATION

READ AND UNDERSTAND ALL OF THE OPERATING INSTRUCTIONS, SAFETY PRECAUTIONS AND WARNINGS IN THIS MANUAL BEFORE OPERATING OR MAINTAINING THIS NAILER.

Most accidents that result from the operation and maintenance of Nailers are caused by the failure to observe basic safety rules or precautions. An accident can often be avoided by recognizing a potentially hazardous situation before it occurs, and by observing appropriate safety procedures.

Basic safety precautions are outlined in the "SAFETY" section of this Manual and in the sections which contain the operation and maintenance instructions.

Hazards that must be avoided to prevent bodily injury or machine damage are identified by DANGERS and WARNINGS on the Nailer and in this Manual.

Never use this Nailer for applications other than those specified in this Manual.

DEFINITIONS OF SIGNAL WORDS

DANGER indicates an imminently hazardous situation which, if not avoided, will result in death or serious injury.

WARNING indicates a potentially hazardous situation which, if not avoided, could result in death or serious injury.

CAUTION indicates a potentially hazardous situation which, if not avoided, may result in minor or moderate injury, or may cause machine damage.

NOTE emphasizes essential information.

SAFETY

IMPORTANT SAFETY INSTRUCTIONS

FOR USING NAILERS

READ ALL INSTRUCTIONS

DANGER

1. ALWAYS WEAR EYE PROTECTOR.

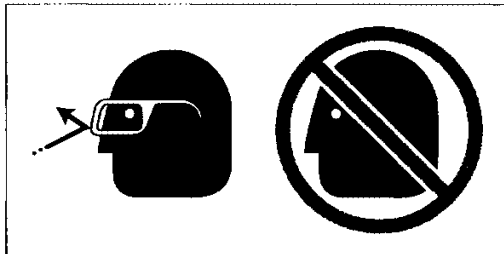

When operating the Nailer, always wear eye protector, and make sure others in work area wear eye protector, too.

Eye protector must conform to the requirements of American National Standards Institute, ANSI Z87.1 and provide protection against flying particles both from the front and side.

The employer must enforce the use of eye protector by the Nailer operator and others in work area.

2. NEVER USE BOTTLED GASES.



Never use oxygen, combustible gases or any other bottled gases as a power source for the Nailer.

Use of the above gases is dangerous, as the Nailer will explode. Use only clean, dry, regulated compressed air.

WARNING

3. DO NOT EXCEED 120 psi.

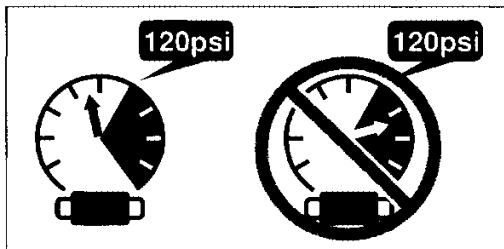

Do not exceed maximum recommended air pressure 120 psi (8.3 bar 8.5 kgf/cm²).

Never connect the Nailer to pressure which potentially exceeds 200 psi (13.7 bar 14 kgf/cm²) as the Nailer can burst.

4. NEVER POINT NAILER TOWARD YOURSELF OR ANYONE ELSE.

Always assume the Nailer contains fasteners.

Never point the Nailer toward yourself or anyone else, whether it contains fasteners or not.

If fasteners are mistakenly driven, it can lead to severe injuries.

Never engage in horseplay with the Nailer.

Respect the Nailer as a working implement.

- 5. NEVER CARRY WITH FINGER ON TRIGGER.**

Remove finger from trigger when not driving fasteners.
Never carry the Nailer with finger on trigger since you could drive a fastener unintentionally and injure yourself or someone else.
Always carry the Nailer by the handle only.
- 6. ALWAYS WEAR EAR AND HEAD PROTECTOR.**

Always wear ear protector to protect your ears from loud noise.
Always wear head protector to protect your head from flying objects.
- 7. STORE NAILER PROPERLY.**

When not in use, the Nailer should be stored in a dry place. Keep out of reach of children. Lock the storage area.
- 8. KEEP WORK AREA CLEAN.**

Cluttered areas invite injuries. Clear all work areas of unnecessary tools, debris, furniture, etc.
- 9. NEVER USE IN PRESENCE OF FLAMMABLE LIQUIDS OR GASES.**

The Nailer produces sparks during operation.
Never use the Nailer in sites containing lacquer, paint, benzine, thinner, gasoline, gases, adhesive agents, and other materials which are combustible or explosive.
- 10. KEEP VISITORS AWAY.**

Do not let visitors handle the Nailer.
All visitors should be kept safely away from work area.
- 11. DRESS PROPERLY.**

Do not wear loose clothing or jewelry as they can be caught in moving parts. Rubber gloves and nonskid footwear are recommended when working outdoors.
Wear protective hair covering to contain long hair.
- 12. NEVER USE NON RELIEVING COUPLER ON NAILER.**

If a non relieving coupler is used on the Nailer, the Nailer can remain charged with air after disconnecting and thus will be able to drive a fastener even after disconnecting.
The Nailer and air hose must have a hose coupling such that all pressure is removed from the Nailer when the coupling joint is disconnected.
- 13. CHECK PUSH LEVER BEFORE USE.**

Make sure the push lever operates properly. (The push lever may be called "Safety".) Never use the Nailer unless the push lever is operating properly, otherwise the Nailer could drive a fastener unexpectedly. Do not tamper with or remove the push lever, otherwise the push lever becomes inoperable.
- 14. KEEP ALL SCREWS AND COVERS TIGHTLY IN PLACE.**

Keep all screws and covers tightly mounted. Check their condition periodically.
Never use the Nailer if parts are missing or damaged.
- 15. DO NOT LOAD FASTENERS WITH TRIGGER PULLED OR PUSH LEVER DEPRESSED.**

When loading fasteners into the Nailer or when connecting the air hose.

 - 1) do not pull the trigger;
 - 2) do not depress the push lever; and
 - 3) keep the Nailer pointed downward.

SAFETY – Continued

- 16. KEEP HANDS AND FEET AWAY FROM FIRING HEAD DURING USE.**
Never place your hands or feet closer than 8 inches from the firing head. A serious injury can result if the fasteners are deflected by the workpiece, or are driven away from the point of entry.
- 17. PLACE NAILER PROPERLY ON WORKPIECE.**
Do not drive fasteners on top of other fasteners or with the Nailer at too steep of an angle; the fasteners can ricochet and hurt someone.
- 18. BE CAREFUL OF DOUBLE FIRE DUE TO RECOIL.**
If the push lever is unintentionally allowed to re-contact the workpiece following recoil, an unwanted fastener will be driven.
In order to avoid this undesirable double fire.
- 1) do not push the Nailer on the workpiece with strong force;
 - 2) take the Nailer completely away from the workpiece using recoil, and keep the push lever away from the workpiece until the next desirable shot; and
 - 3) pull the trigger and release it QUICKLY when performing intermittent operation (trigger fire).
- 19. DO NOT DRIVE FASTENERS INTO THIN BOARDS OR NEAR CORNERS AND EDGES OF WORKPIECE.**
The fasteners can be driven through or away from the workpiece and hit someone.
- 20. NEVER DRIVE FASTENERS FROM BOTH SIDES OF A WALL AT THE SAME TIME.**
The fasteners can be driven into and through the wall and hit a person on the opposite side.
- 21. CHECK FOR LIVE WIRES.**
Avoid the risk of severe electrical shock by checking for live electrical wires that may be hidden by walls, floors or ceilings. Turn off the breaker switch to ensure there are no live wires.
- 22. NEVER CARRY NAILER BY HOSE.**
- 23. DO NOT OVERREACH.**
Keep proper footing and balance at all times.
- 24. NEVER USE NAILER WHICH IS DEFECTIVE OR OPERATING ABNORMALLY.**
If the Nailer appears to be operating unusually, making strange noises, or otherwise appears defective, stop using it immediately and arrange for repairs by a Hitachi authorized service center.
- 25. DO NOT DISCONNECT AIR HOSE FROM NAILER WITH FINGER ON TRIGGER.**
The Nailer can fire when re-connected to an air supply.
- 26. DISCONNECT AIR HOSE FROM NAILER WHEN:**
- 1) doing maintenance and inspection;
 - 2) attaching or removing the nose cap;
 - 3) clearing a jam;
 - 4) it is not in use;
 - 5) leaving work area;

- 6) moving it to another location; and
- 7) handing it to another person.

Never attempt to clear a jam or repair the Nailer unless you have disconnected air hose from the Nailer and removed all remaining fasteners from the Nailer.

The Nailer should never be left unattended since people who are not familiar with the Nailer might handle it and injure themselves.

27. STAY ALERT.

Watch what you are doing. Use common sense.

Do not operate the Nailer when you are tired.

The Nailer should never be used by you if you are under the influence of alcohol, drugs or medication that makes you drowsy.

28. HANDLE NAILER CORRECTLY.

Operate the Nailer according to this Manual.

Never allow the Nailer to be operated by children, individuals unfamiliar with its operation or unauthorized personnel.

29. NEVER USE NAILER FOR APPLICATIONS OTHER THAN THOSE SPECIFIED IN THIS MANUAL.

30. HANDLE NAILER CAREFULLY.

Because of high air pressure in the Nailer, cracks in the surface are dangerous.

To avoid this, do not drop the Nailer or strike the Nailer against hard surfaces; and do not scratch or engrave signs on the Nailer.

Handle the Nailer carefully.

31. MAINTAIN NAILER WITH CARE.

Keep the Nailer clean and lubricated for better and safer performance.

32. USE ONLY PARTS, ACCESSORIES OR FASTENERS SUPPLIED OR RECOMMENDED BY HITACHI.

Unauthorized parts, accessories, or fasteners may void your warranty and can lead to malfunction and resulting injuries.

Only service personnel trained by Hitachi, distributor or employer shall repair the Nailer.

Do not modify the Nailer without the written approval of Hitachi.

EMPLOYER'S RESPONSIBILITIES

1. Ensure that this MANUAL is available to operators and personnel performing maintenance.
2. Ensure that Nailers are used only when operators and others in work area are wearing EYE PROTECTOR.
3. Enforce the use of EYE PROTECTOR by operators and others in work area.
4. Keep Nailers in safe working order.
5. Maintain Nailers properly.
6. Ensure that Nailers which require repair are not further used before repair.

SAVE THIS MANUAL AND KEEP IT AVAILABLE FOR OTHERS!

OPERATION

NOTE:

The information contained in this Manual is designed to assist you in the safe operation of the Nailer.

Some illustrations in this Manual may show details or attachments that differ from those on your own Nailer.

NAME OF PARTS

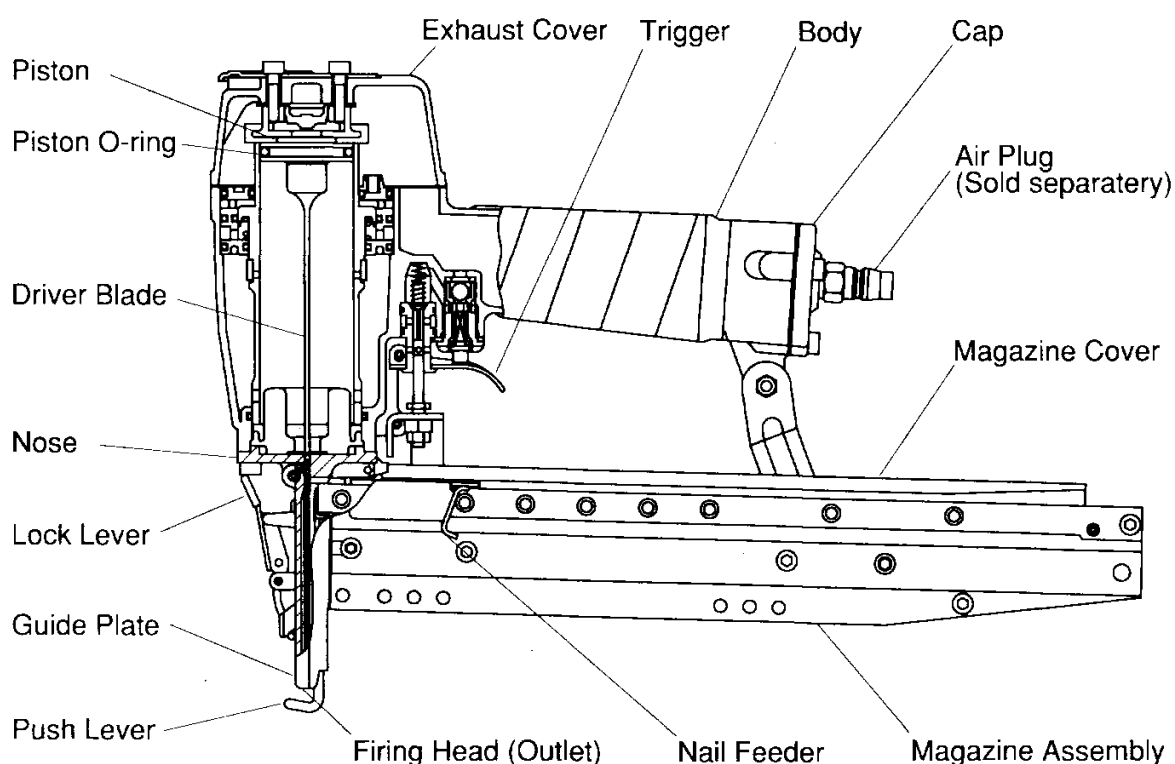



SPECIFICATIONS

Operating pressure	70 – 120 psi (4.9 – 8.3 bar 5 – 8.5 kgf/cm ²)
Dimensions Length×Height×Width	14-31/32"×10"×3" (380mm × 254mm × 76mm)
Weight	4.4 lbs (2.0 kg)
Nail capacity	150 Nails
Air consumption	.031 ft ³ /cycle at 100 psi (.88 ltr/cycle at 6.9 bar) (.88 ltr/cycle at 7 kgf/cm ²)
Air inlet	3/8 NPT Thread

NAIL SELECTION

Only nails shown in the Table below can be driven with this Nailer.

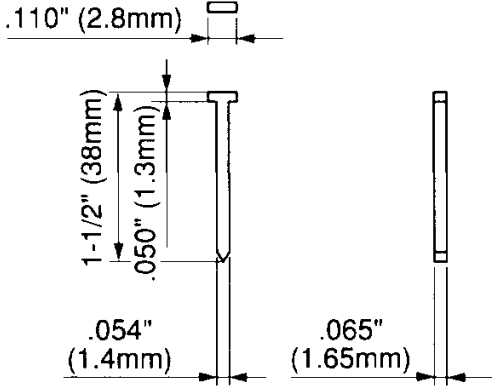
Dimensions of nails

16 Gauge Finsh	
Min.	Max.
 <p>.110" (2.8mm)</p> <p>1-1/2" (38mm)</p> <p>.050" (1.3mm)</p> <p>.054" (1.4mm)</p> <p>.065" (1.65mm)</p>	 <p>2-1/2" (65mm)</p>

ACCESSORIES

⚠ WARNING

- Accessories other than those shown below can lead to malfunction and resulting injuries.

STANDARD ACCESSORIES

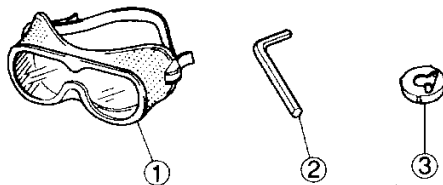

①	Eye protector	1
②	Allen wrench for M5 screw	1
③	Nose Cap	1

OPTIONAL ACCESSORIES...sold separately

- Pneumatic Tool Lubricant
 - 1 oz. (30cc) oil feeder (Code No. 877153)
 - 4 oz. (120cc) oil feeder (Code No. 874042)
 - 1 quart (1 ltr) can (Code No. 876212)

NOTE : Accessories are subject to change without any obligation on the part of HITACHI.

APPLICATIONS

- Nailing as a finishing process for areas around the doors, windows as well as edgings.
- Securing the bottom of drawers. Making various cases and cabinets.

BEFORE OPERATION

Read section titled "SAFETY" (page 4-7).

Make sure of the followings before operation.

WORKING ENVIRONMENT

⚠ WARNING

- No flammable gas, liquid or other flammable objects at worksite.
- Clear the area of children or unauthorized personnel.

AIR SUPPLY

⚠ DANGER



- Never use oxygen, combustible gases or any other bottled gases.

⚠ WARNING

- **Never connect Nailer to pressure which potentially exceeds 200 psi (13.7 bar 14 kgf/cm²)**
- **Never use non relieving coupler on Nailer.**

1. Power source

- Use only clean, dry, regulated compressed air as a power source for this Nailer.
- Air compressors used to supply compressed air to this Nailer must comply with the requirements of the latest version of ANSI Standard B 19.3 "Safety Standard For Compressors For Process Industries."
- Moisture or oil in the air compressor may accelerate wear and corrosion in the Nailer.
Drain daily.

2. Filter-Regulator-Lubricator

- Use a regulator with a pressure range of 0 — 120 psi (0 — 8.3 bar 0 — 8.5 kgf/cm²).
- Filter-regulator-lubricator units supply an optimum condition for the Nailer and extend the Nailer life. These units should always be used.
 FilterThe filter removes moisture and dirt mixed in compressed air.
 Drain daily unless fitted with an automatic drain.
 Keep the filter clean by regular maintenance.
 RegulatorThe regulator controls the operating pressure for safe operation of the Nailer.
 Inspect the regulator before operation to be sure it operates properly.
 LubricatorThe lubricator supplies an oil mist to the Nailer.
 Inspect the lubricator before operation to be sure the supply of lubricant is adequate.
 Use Hitachi pneumatic tool lubricant.

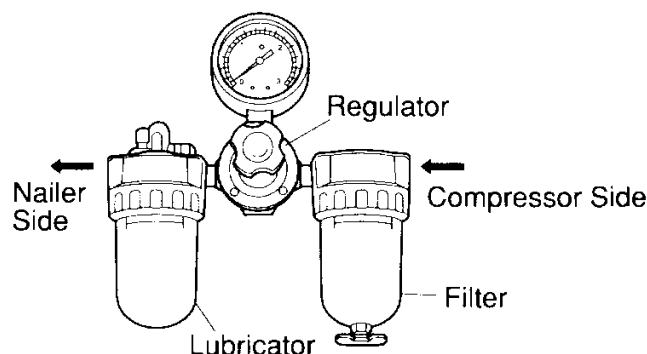

3. Air hose

- Air hose must have a minimum working pressure rating of 150 psi (10.4 bar 10.6 kgf/cm²) or 150% of the maximum pressure produced in the system, whichever is higher.

4. Hose coupling

- The Nailer can be installed as follows:
Remove the dust cap placed at the air inlet.
Install a 3/8 NPT male plug at the air inlet.
- A female coupler must be on the air hose.
The hose coupling (male plug–female coupler) must remove all pressure from the Nailer when disconnected.
Never use a non relieving coupler on the Nailer.

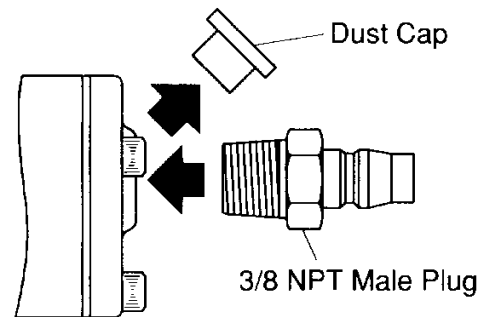

5. Air consumption

- Using the Air consumption table and the Air compressor size formula, find a correct compressor size.

Air consumption table

	psi	80	90	100
Operating pressure	(bar)	(5.5)	(6.2)	(6.9)
	(kgf/cm ²)	(5.6)	(6.3)	(7)
Air consumption	ft ³ /cycle	.023	.027	.031
	(ltr/cycle)	(.65)	(.76)	(.88)

Air compressor size formula

Amount of air required

=number of Nailers

× average nails driven each minute per Nailer

× air consumption at given air pressure

× safety factor (always 1.2)

Example: 3 Nailers (NT65A2) operating at 100 psi driving 30 Nails per minute.

Amount of air required

=3 × 30 × .031 (.88) × 1.2

=3.3 CFM (ft³/min)(95 ltr/min)

After making the calculations as shown above, you should find a compressor providing 3.3 CFM of air that is required.

LUBRICATION

It is important that the Nailer be properly lubricated.

Without proper lubrication, the Nailer will not work properly and parts will wear prematurely.

- Use Hitachi pneumatic tool lubricant.
Do not use detergent oil or additives. These lubricants will harm the O-rings and other rubber parts. This will cause the Nailer to malfunction.
- Filter-regulator-lubricator units should always be used. Keep the lubricator filled with Hitachi pneumatic tool lubricant.
- If a lubricator is not available, supply 2–3 drops of Hitachi pneumatic tool lubricant into the air plug on the Nailer twice a day.

COLD WEATHER CARE

- Do not store the Nailer in a cold weather environment. Keep the Nailer in a warm area until beginning the work.
- If the Nailer is already cold, bring it in a warm area and allow the Nailer to warm up before use.
 - ① Reduce the air pressure to 40 psi (2.8 bar 2.8 kgf/cm²).
 - ② Remove all nails from the Nailer.
 - ③ Connect the air hose and free-fire (blank-fire) the Nailer.
The lowered air pressure will be enough to free-fire the Nailer.
Slow speed operation tends to warm up the moving part.

⚠ CAUTION

- Do not free-fire the Nailer at high pressure.

TESTING THE NAILER

⚠ DANGER

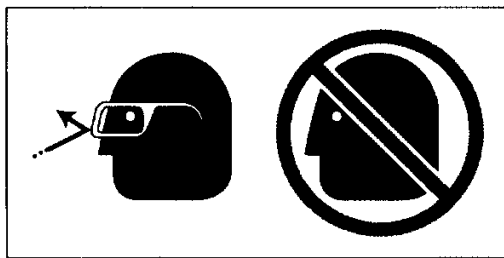

- Always wear eye protector.

⚠ WARNING

- Never use Nailer unless push lever is operating properly.

Before actually beginning the nailing work, test the Nailer by using the checklist below. Conduct the tests in the following order.

If abnormal operation occurs, stop using the Nailer and contact a Hitachi authorized service center immediately.

- (1) DISCONNECT AIR HOSE FROM NAILER
REMOVE ALL NAILS FROM NAILER.

- ALL SCREWS MUST BE TIGHTENED.
If any screws are loose, tighten them.

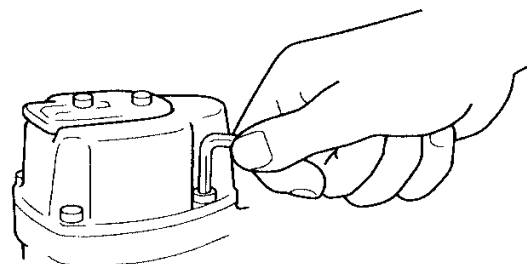

- THE PUSH LEVER AND TRIGGER MUST MOVE SMOOTHLY.

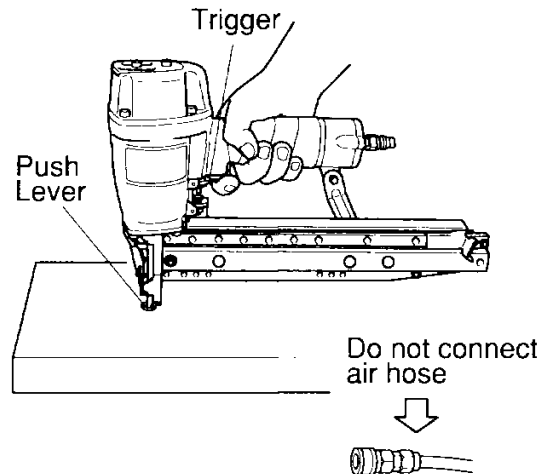

- (2) Adjust the air pressure to 70 psi (4.9 bar 5 kgf/cm²).
Connect the air hose.
Do not load any nails in the Nailer.

- THE NAILER MUST NOT LEAK AIR.

Hold the Nailer downward and pull the trigger.

- THE NAILER MUST NOT OPERATE.

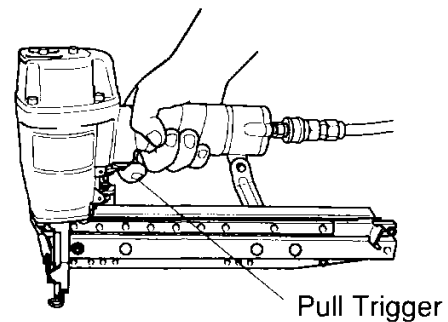

- (3) With finger off the trigger, depress the push lever against the workpiece.

- THE NAILER MUST NOT OPERATE.

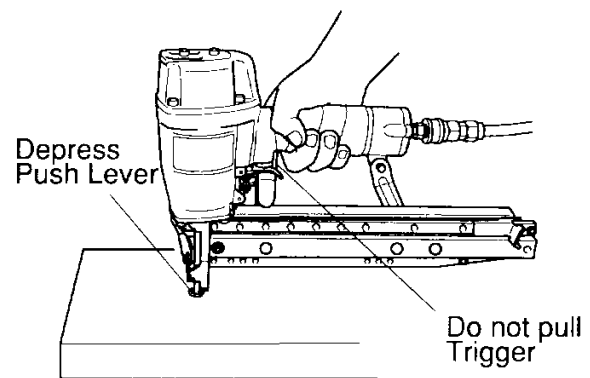

- (4) Without touching the trigger, depress the push lever against the workpiece.
Pull the trigger.

- THE NAILER MUST OPERATE.

- (5) With the Nailer off the workpiece, pull the trigger.
Depress the push lever against the workpiece.
- THE NAILER MUST OPERATE.
- (6) If no abnormal operation is observed, you may load nails in the Nailer.
Drive nails into the workpiece that is the same type to be used in the actual application.
- THE NAILER MUST OPERATE PROPERLY.

ADJUSTING AIR PRESSURE

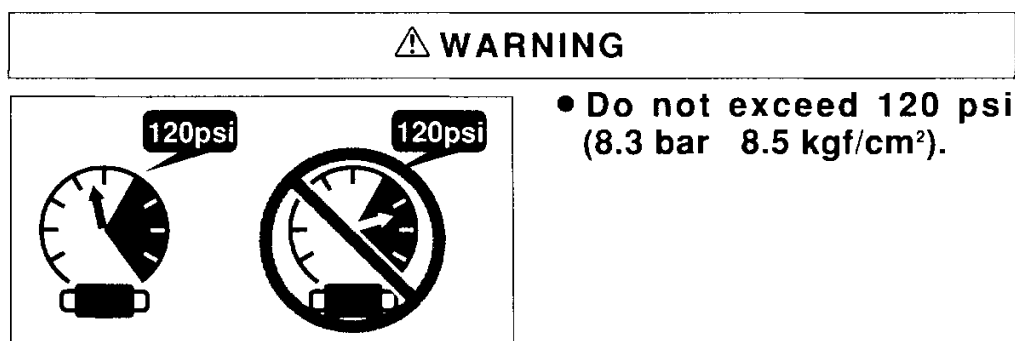

Adjust the air pressure at recommended operating pressure 70 — 120 psi (4.9 — 8.3 bar 5 — 8.5 kgf/cm²) according to the length of nails and the hardness of workpiece.

The correct air pressure is the lowest pressure which will do the job. Using the Nailer at a higher than required air pressure unnecessarily over stresses the Nailer.

LOADING NAILS



- When loading nails into Nailer,
 - 1) do not pull trigger;
 - 2) do not depress push lever; and
 - 3) keep Nailer pointed downward.

- (1) Pull the nail feeder back and hang it over the roll pin.

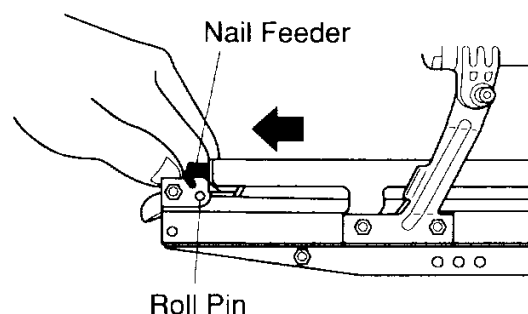

- (2) ① Insert nail strips one by one from above the magazine.
 ② Slide nails forward in the magazine.

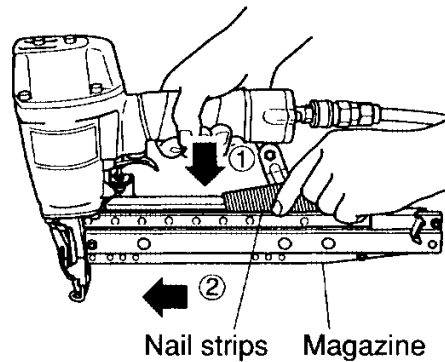

- (3) ① Pull the nail feeder up in backward direction and remove it from the roll pin.
 ② Slide the nail feeder forward until it contacts nails.

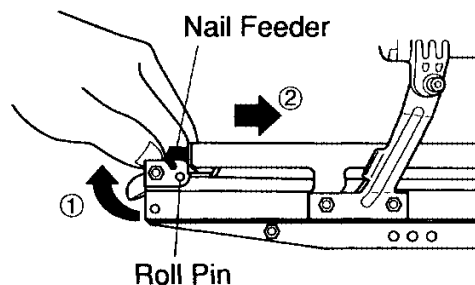

NOTE:

- Use nails at least 5 nails remaining.

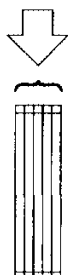

- Slide the nail feeder **SLOWLY** forward. If the nail feeder is released roughly, it may be stuck between the magazine and nails, which makes mis-feeding trouble.

NAILER OPERATION

Read section titled "SAFETY" (pages 4-7).

⚠ DANGER

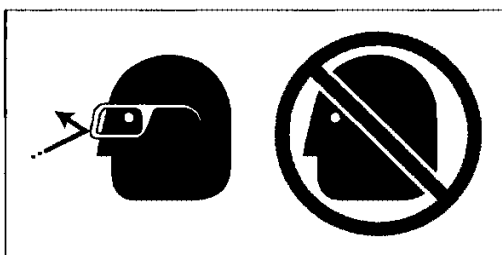

- Always wear eye protector.

⚠ WARNING

- **Never point Nailer toward yourself or anyone else.**
- **Never carry with finger on trigger.**
Remove finger from trigger when not driving nails.
- **Never place your hands or feet closer than 8 inches (200mm) from firing head when using.**
- **Do not drive nails on top of other nails or with Nailer at too steep of an angle; nails can ricochet and hurt someone.**
- **In order to avoid double fire,**
 - 1) **do not push Nailer on workpiece with strong force;**
 - 2) **take Nailer away from workpiece using recoil;**
 - 3) **release trigger quickly when performing trigger fire.**
- **Do not drive nails into thin boards or near corners and edges of workpiece. Nails can be driven through or away from workpiece and hit someone.**
- **Never drive nails from both sides of a wall at the same time. Nails can be driven into and through the wall and hit a person on the opposite side.**
- **Never use Nailer which is defective or operating abnormally.**
- **Do not use Nailer as hammer.**
- **Disconnect air hose from Nailer when:**
 - 1) **attaching or removing nose cap;**
 - 2) **it is not in use;**
 - 3) **leaving work area;**
 - 4) **moving it to another location; and**
 - 5) **handing it to another person.**

METHODS OF OPERATION

This Nailer is equipped with the push lever and does not operate unless the push lever is depressed (upward position).

There are two methods of operation to drive nails with this Nailer.

They are:

1. Intermittent operation (Trigger fire):
 2. Continuous operation (Push lever fire):
- (1) Intermittent operation (Trigger fire)

- ① Position the nail outlet on the workpiece with finger off the trigger.
- ② Depress the push lever firmly until it is completely depressed.
- ③ Pull the trigger to drive a nail.
- ④ Remove finger from the trigger.

To drive another nail, move the Nailer along the workpiece and repeat this procedure.

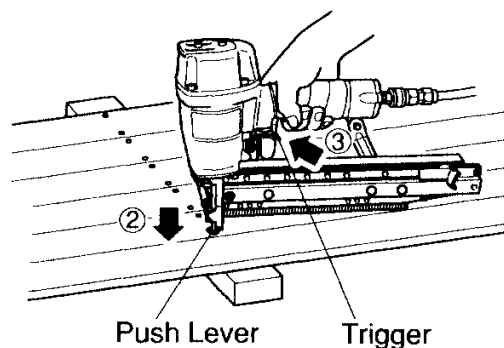

(2) Continuous operation (Push lever firing)

- ① Pull the trigger with the Nailer off the workpiece.
- ② Depress the push lever against the workpiece to drive a nail.
- ③ Move the Nailer along the workpiece with a bouncing motion.
Each depression of the push lever will drive a nail.

As soon as the desired number of nails have been driven, remove finger from the trigger.

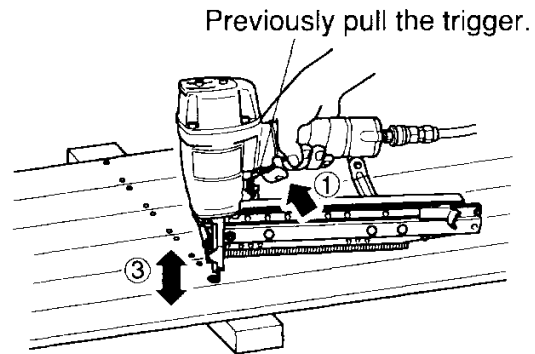
**NOTE:**

- Always handle nails and package carefully. If nail strips are dropped, collating bond may be broken, which will cause mis-feeding and jamming.
- After nailing:
 - 1) disconnect air hose from the Nailer;
 - 2) remove all nails from the Nailer;
 - 3) supply 2—3 drops of Hitachi pneumatic tool lubricant into the air plug on the Nailer; and
 - 4) open the petcock on the air compressor tank to drain any moisture.

USING THE NOSE CAP

If you like to protect the surface of workpiece against scratches or markings made by the push lever, attach the accessory nose cap to the push lever.

- ① DISCONNECT AIR HOSE FROM NAILER.
- ② Put the nose cap to the toe of the push lever.

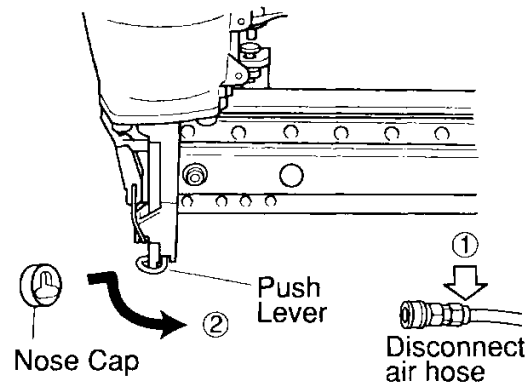
**NOTE:**

- The nose cap may reduce nailing depth due to its thickness. Re-adjustment of nailing depth is required.

MAINTENANCE

NOTE:

The information contained in this Manual is designed to assist you in the safe maintenance of the Nailer.

Some illustrations in this Manual may show details or attachments that differ from those on your own Nailer.

MAINTENANCE AND INSPECTION

Read section titled "SAFETY" (pages 4-7).

⚠ WARNING

- **Disconnect air hose and remove all nails from Nailer when:**
 - 1) **doing maintenance and inspection; and**
 - 2) **clearing jam.**

1. Clearing a jam

Remove a jammed nail in the following order:

- ① DISCONNECT AIR HOSE.
- ② Remove all nails.
- ③ Release the lock lever and open guide plate.
- ④ Remove the jammed nail with a slotted-head screwdriver.
- ⑤ Close guide plate and latch.
- ⑥ In case of frequent jam, contact a Hitachi authorized service center.

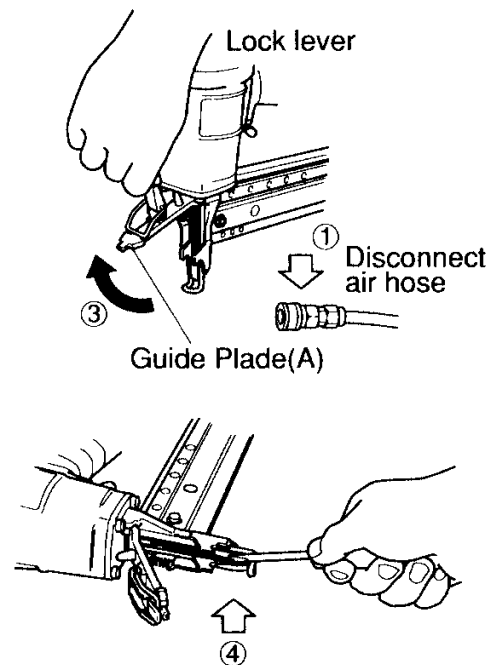

2. Maintenance chart ...See page 20.

3. Operator troubleshooting...See page 21.

4. Storing

- When not in use for an extended period, apply a thin coat of the lubricant to the steel parts to avoid rust.
- Do not store the Nailer in a cold weather environment. Keep the Nailer in a warm area.
- When not in use, the Nailer should be stored in a warm and dry place. Keep out of reach of children.

5. WARNING LABEL

Change the WARNING LABEL if missing or damaged. A new WARNING LABEL is available from a Hitachi authorized service center.

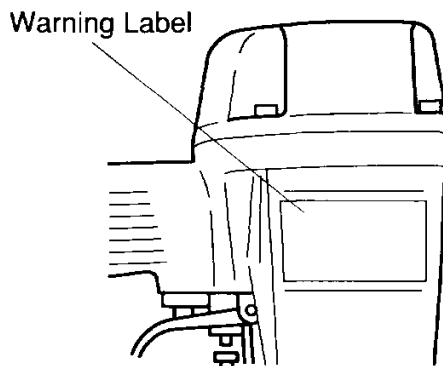

SERVICE AND REPAIRS

⚠ WARNING

- Only service personnel trained by Hitachi, distributor or employer shall repair the Nailer.
- Use only parts supplied or recommended by Hitachi for repair.

All quality Nailers will eventually require servicing or replacement of parts because of wear from normal use.

NOTE:

Specifications are subject to change without any obligation on the part of HITACHI.



Maintenance chart

ACTION	WHY	HOW
Drain air line filter daily.	Prevent accumulation of moisture and dirt.	Open manual petcock.
Keep lubricator filled.	Keep the Nailer lubricated.	Fill with Hitachi pneumatic tool lubricant.
Clean filter element—then blow air through filter in direction opposite to normal flow.	Prevent clogging of filter with dirt.	Follow manufacturer's instructions.
Clean magazine and feeder mechanism.	Prevent a jam.	Blow clean daily.
Keep push lever working properly.	Promote operator safety and efficient Nailer operation.	Blow clean daily.
Lubricate the Nailer after nailing.	Extend the Nailer life.	Supply 2–3 drops of lubricant into the Nailer.
Drain air compressor.	Keep the Nailer operated properly.	Open petcock on air compressor tank.

Operator troubleshooting

Most minor problems can be resolved quickly and easily using the table below. If problems persist, contact a Hitachi authorized service center for assistance.

PROBLEM	CHECK METHOD	CORRECTION
Nailer operates but no nail is driven.	Check for a jam.	Clean a jam per page 19.
	Nail feeder damaged ?	Replace nail feeder.
	Ribbon spring weakened or damaged ?	Replace ribbon spring.
	Check for proper nails.	Use only recommended nails.
Weak drive. Slow to cycle.	Check air pressure.	Increase air pressure. (Do not exceed 120 psi (8.3 bar 8.5 kgf/cm ²))
	—	Use Hitachi pneumatic tool lubricant.
	Driver blade worn ?	Contact Hitachi for replacement.
	Piston O-ring worn or damaged ?	
Drives too deep.	Check air pressure.	Reduce air pressure. (Adjust 70-120 psi)
Skipping nails. Intermittent feed.	Check for proper nails.	Use only recommended nails.
	Nail feeder damaged ?	Replace nail feeder.
	Ribbon spring weakened or damaged ?	Replace ribbon spring.
	Piston O-ring worn or damaged ?	Contact Hitachi for replacement.
Nails jam. Driven nail is bent.	Check for proper nails.	Use only recommended nails.
	Driver blade worn ?	Contact Hitachi for replacement.
Drives properly during normal operation, but does not drive fully at faster nailing speeds.	Check inside diameter of air hose.	Use larger air hose.

Hitachi Koki Co., Ltd.

Nippon Bldg., 6-2 Ohtemachi 2-chome,
chiyoda-ku, Tokyo 100-0004, Japan

803

Code No. C99089161 A

Printed in Japan